

XTOOL | Safety Set

使用者手冊

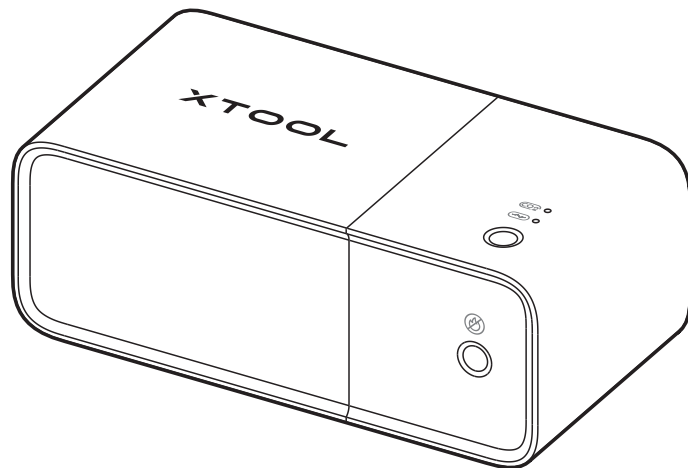

概述	01
物品清單	02
認識火焰安全裝置	03
安裝火焰安全裝置	04
使用前準備	04
使用火焰安全裝置	08
維護	15

概述

xTool 火焰安全裝置是一款專為桌上型雷射加工產品設計的安全輔助工具，透過火焰感測器對設備的工作區域進行監測，檢測到火焰就會觸發警報，火焰較大時還能觸發滅火動作，自動完成從監測到滅火的完整過程。

工作環境溫度	0°C~35°C
存放溫度	0°C~45°C
支援的最大加工空間	0.13 立方公尺

物品清單

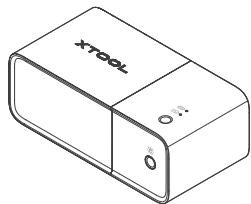

控制盒

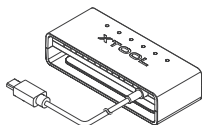

感測器集線盒

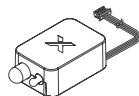

感測器 1



感測器 2

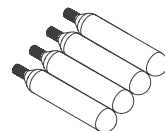

氣瓶

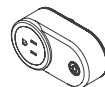

智慧開關

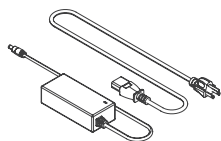

電源適配器 & 電源線



xTool P2 連接線

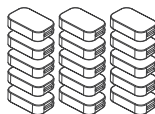

線夾



氣管夾

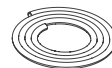

氣管

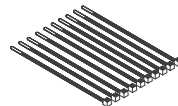

纜線紮帶包

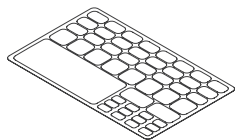

3M 膠帶



換氣瓶提示貼紙



使用手冊



安全說明



不同套組包含的智慧開關
可能會有所不同，圖片僅
供參考，請以實際材料為
準。

認識火焰安全裝置

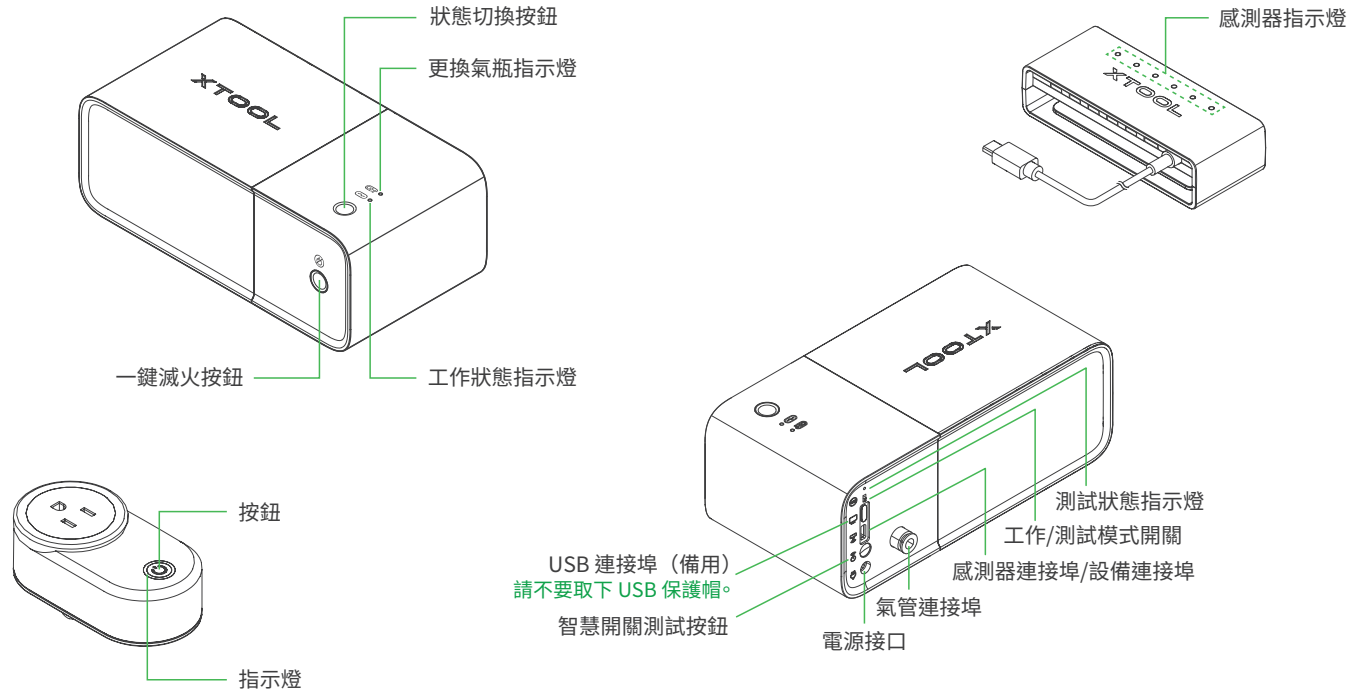

安裝火焰安全裝置

火焰安全裝置的安裝方式以實際設備為準。

若使用 xTool 設備，請前往 support.xtool.com/product/17 或掃描 QR code，查看火焰安全裝置的詳細安裝步驟。若使用他牌設備，可參考 xTool 類似機型的安裝方式進行安裝。



support.xtool.com/product/17

使用前準備

1. 進入測試模式

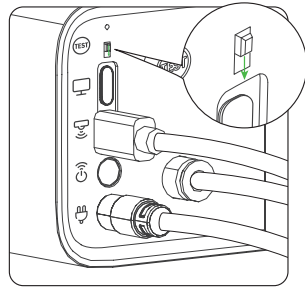

將開關撥到測試模式

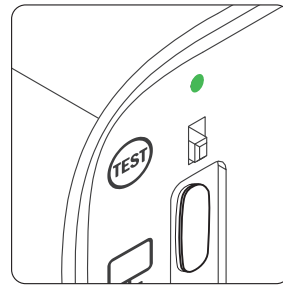

恆亮

2. 將控制盒和智慧開關配對

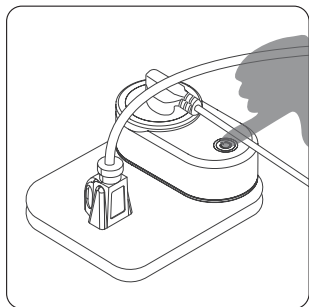

長按 5 秒

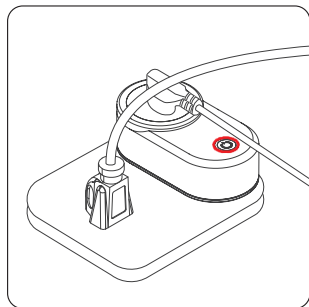

恆亮

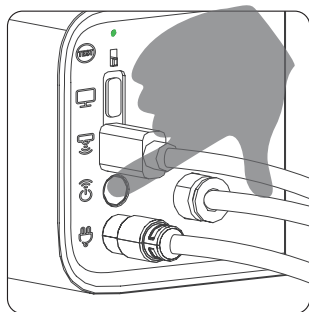

按下

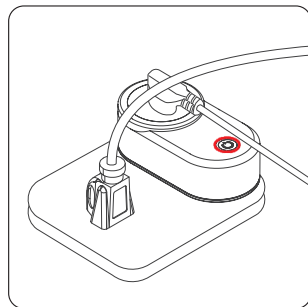

閃爍 3 次後熄滅，配對成功

3. 測試智慧開關的控制

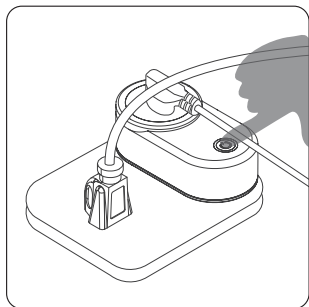

按下

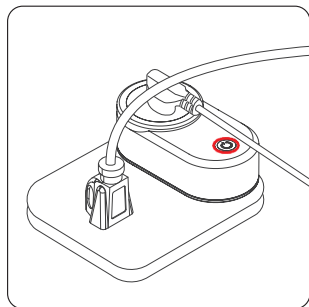

恆亮

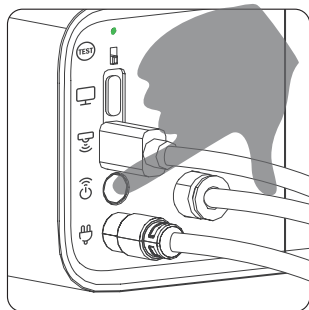

按下

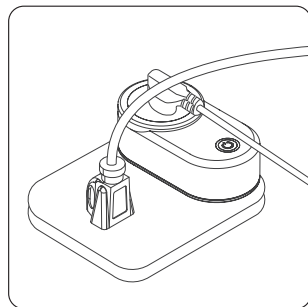

熄滅

4. 測試感測器

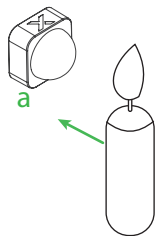

將明火靠近感測器

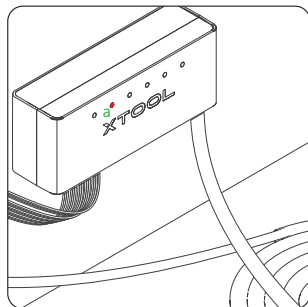

對應的指示燈閃爍

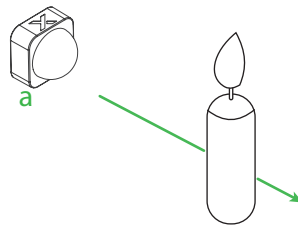

將明火拿開

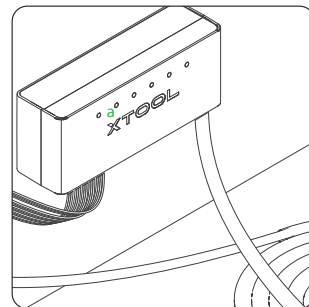

對應的指示燈熄滅

5. 安裝氣瓶



在安裝氣瓶前，請先將火焰安全裝置斷電，避免在安裝過程中誤觸一鍵滅火按鈕，導致觸發滅火動作。

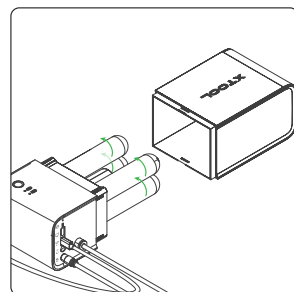
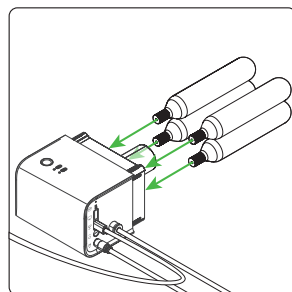
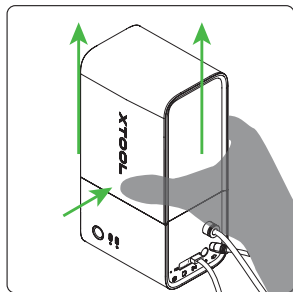
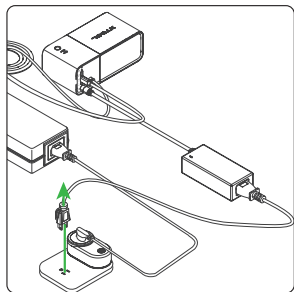

捏住盒子，然後向上拉

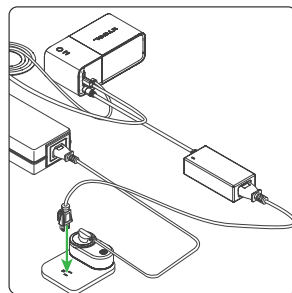
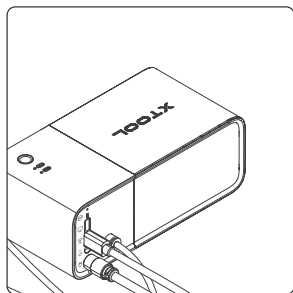
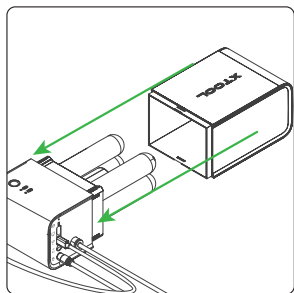

使用火焰安全裝置

自動監測

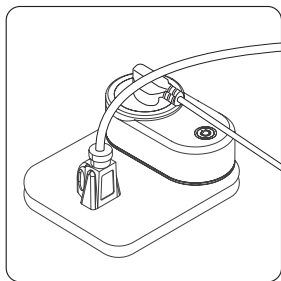

連接電源

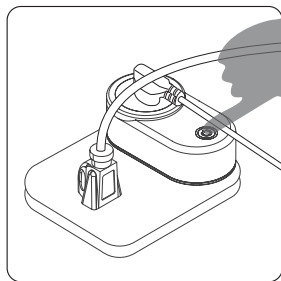

打開開關

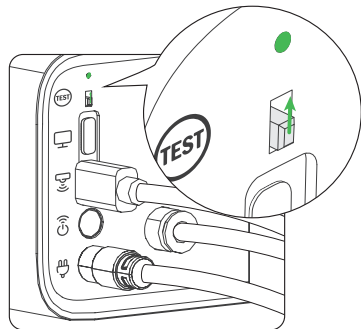

將開關撥到工作模式

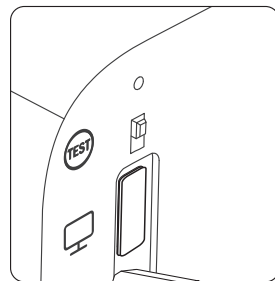

熄滅

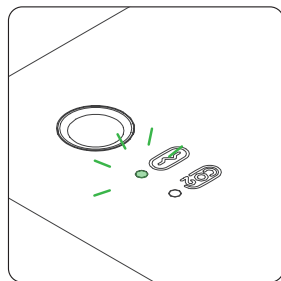

閃爍

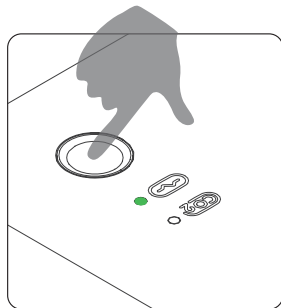

按下

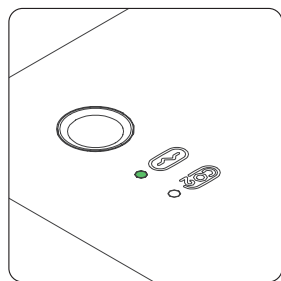

綠色恆亮, 進入監測狀態

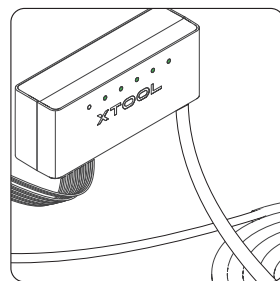

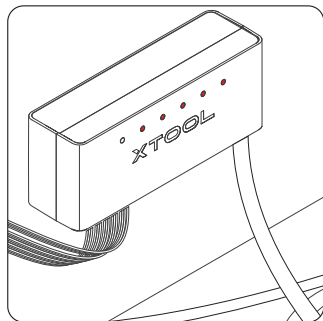

紅色閃爍

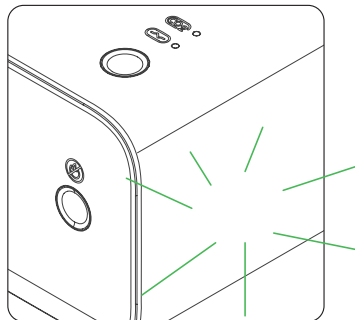

蜂鳴器聲響

檢測到火焰時，感測器指示燈閃爍，蜂鳴器聲響。

- 響聲緩慢：火焰較小，僅觸發警報
- 響聲中速：火焰稍大，僅觸發警報
- 響聲急促：火焰較大，觸發警報和滅火動作

在滅火過程中，氣體會分兩次噴射，間隔約 20 秒。請待滅火過程結束，再觸碰控制盒。

檢測到火焰變小，蜂鳴器響聲逐漸趨緩，火焰熄滅後停止警報。

取消警報

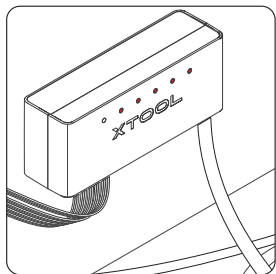

紅色閃爍

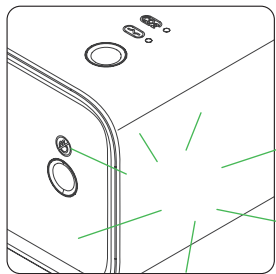

蜂鳴器聲響

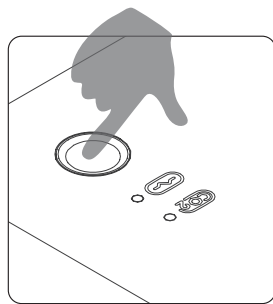

於 5 秒內按下

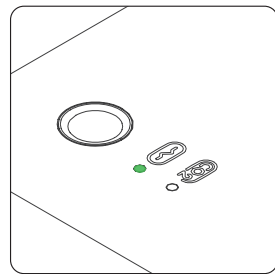

閃爍

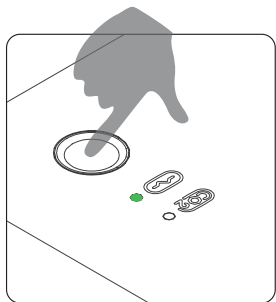

按下

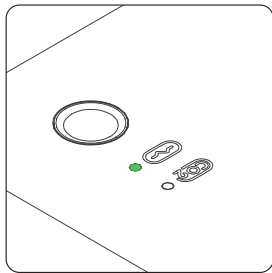

綠色恆亮，進入監測狀態

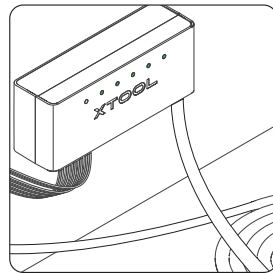

一鍵滅火

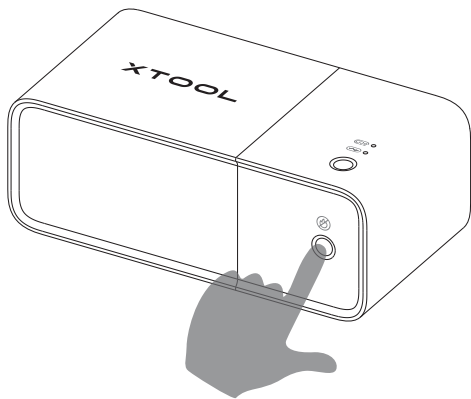

若在工作模式下發現火焰，而須手動滅火，可以按一鍵滅火按鈕，手動觸發滅火動作。

在滅火過程中，氣體會分兩次噴射，間隔約 20 秒。請待滅火過程結束，再觸碰控制盒。

滅火動作一旦觸發就無法取消，請謹慎操作。

更換氣瓶



- 在更換氣瓶前，請先將火焰安全裝置斷電，避免在更換過程中誤觸一鍵滅火按鈕，導致觸發滅火動作。
- 若火焰安全裝置執行過滅火動作，換氣瓶指示燈亮，則須更換氣瓶才可繼續使用。氣瓶須另購。
- 請注意，氣瓶僅供單次作用，噴氣過後請立即更換。

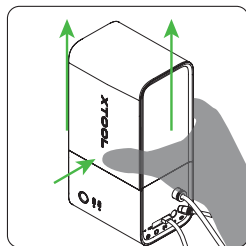
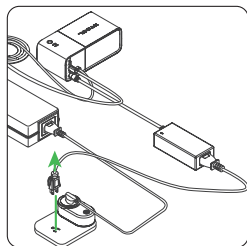
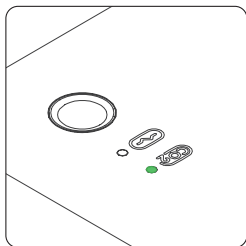

捏住盒子，然後向上拉

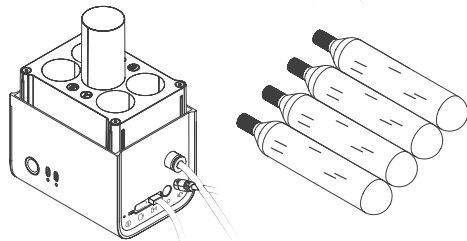
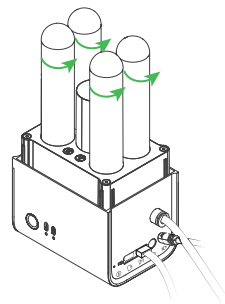

■ 設備加工空間 ≤ 0.065 立方公尺, 可以選擇更換 2 個或 4 個氣瓶

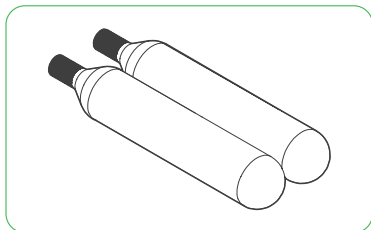

使用 2 個氣瓶時, 請安裝在對角線上, 例如, 都安裝在孔 A, 然後在另外一條對角線上的兩個孔位安裝空氣瓶。

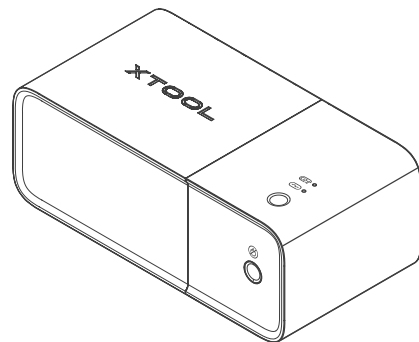
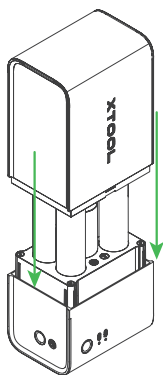
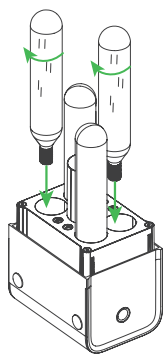
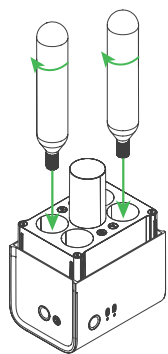

■ 0.065 立方公尺 < 設備加工空間 ≤ 0.13 立方公尺, 須使用 4 個氣瓶

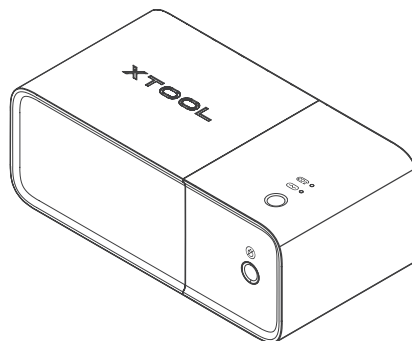
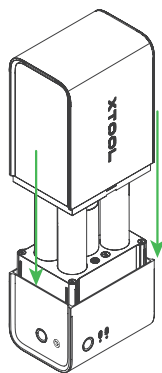
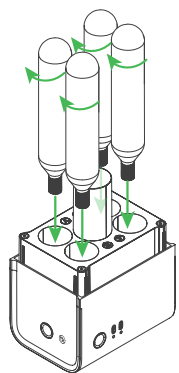
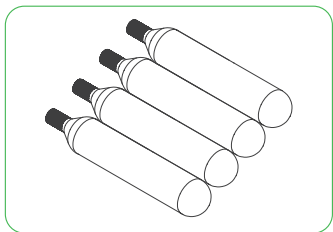

維護

請至少每個月針對以下項目進行一次檢查和維護：

- 清潔感測器
- 檢查感測器是否正常運作
- 檢查智慧開關是否正常運作
- 檢查火焰安全裝置的工作狀態
- 檢查控制盒內的氣瓶是否轉緊